

Grippers pneumatic

Technical Data – Summary

		PG 4	PG 5	PG 6	WG 4	WG 5	WG 6	PG 402	PG 502	PG 505	PG 505-B
Gripping mode:	parallel	●	●	●				●	●	●	●
	angular				●	●	●				
Cylinder diameter [mm]:		10	16	25	16	16	25	12	12	12	12
Theor. gripping force opening [N]:		19,5	50	122,5	39	180	245	41,7	41,7	41,7	41,7
	F _o /F _b										
Theor. gripping force closing [N]:		16,5	46,5	110	33	93	220	41,7	41,7	41,7	41,7
	F _s /F _a										
Theor. gripping moment opening [Ncm]:					8,25	34,8	110				
	M _a										
Theor. gripping moment closing [Ncm]:					9,75	37,5	122,5				
	M _b										
Max. length of gripper jaws [mm]:	l	24	35	48	24	35	48	35	35	35	35
Gripping stroke per side [mm]:	h	3,0	4,5	6,0				5	5	5	5
Effective lever length [mm]:	s				5,00	7,5	10,00				
Distance between axes [mm]:	a				21,00	31,50	42,00				
Gripping angle [°]:	w				1,40	1,40	1,40				
Swivel angle [°]:	v				91,40	91,40	91,40				
Air consumption per cycle at 5 bar and nominal stroke [Nl]:		0,01	0,03	0,11	0,01	0,03	0,11	0,001	0,001	0,001	0,001
Weight [kg]:		0,08	0,30	0,67	0,10	0,37	0,85	0,47	0,49	0,57	0,59
Repeatability [mm]:		+/-0,05	+/-0,05	+/-0,05	+/-0,05	+/-0,05	+/-0,05	+/-0,05	+/-0,05	+/-0,05	+/-0,05
Mass moment of inertia [kg cm ²]		0,067	0,67	2,19	0,067	0,67	2,19	2,29	2,38	2,38	2,58

For all modules

Pneumatic connections:

M5

Parallel Gripper PG 4/5/6



Angle Gripper WG 4/5/6



Difference between PG 502 and PG 505

- PG 502 has a grid adapter plate 30x30 with a direct air lead-through that a pneumatic coupling can be used by the operation of a rotary module.
- PG 505 has a grid adapter plate 30x30 with a direct air lead-through that a pneumatic coupling can be used by the operation of a rotary module. As well as an AF 100 scanning switch-key (presence of a part) which can be shortened by the mounting of the gripper jaw.

Parallel Gripper PG 502

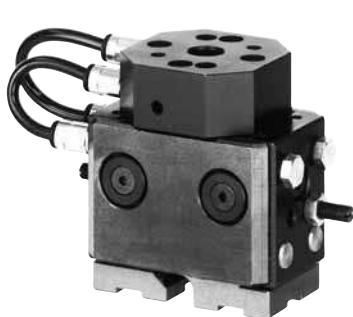

Parallel Gripper PG 505



Grippers pneumatic

Technical Data

Parallel Gripper PG 4/5/6

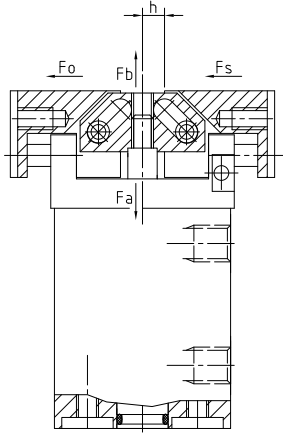

Angle Gripper WG 4/5/6

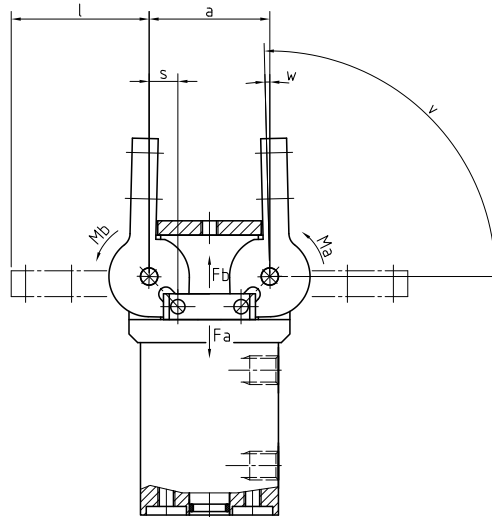

Parallel Gripper PG 402/502/505

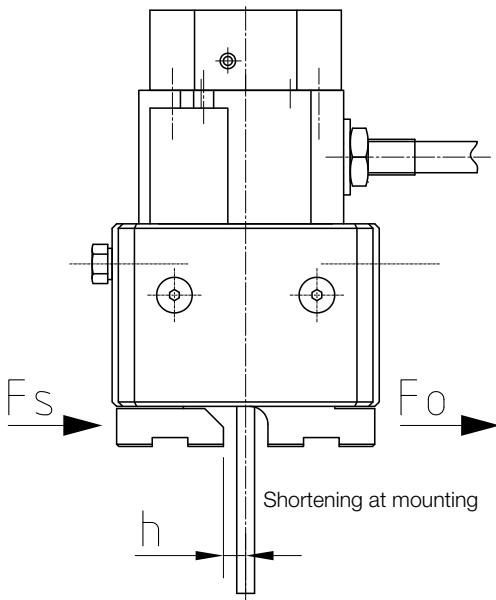

Overview

Linear Axes
pneum. / electr.

Linear Modules
pneum. / electr.

Linear Modules
with Intermediate
Positions

Rotary Modules

Grippers

Basic Elements

Accessories

Grippers pneumatic

PG 402/502 – Parallel Gripper

Dimensional drawing and pneumatic diagram

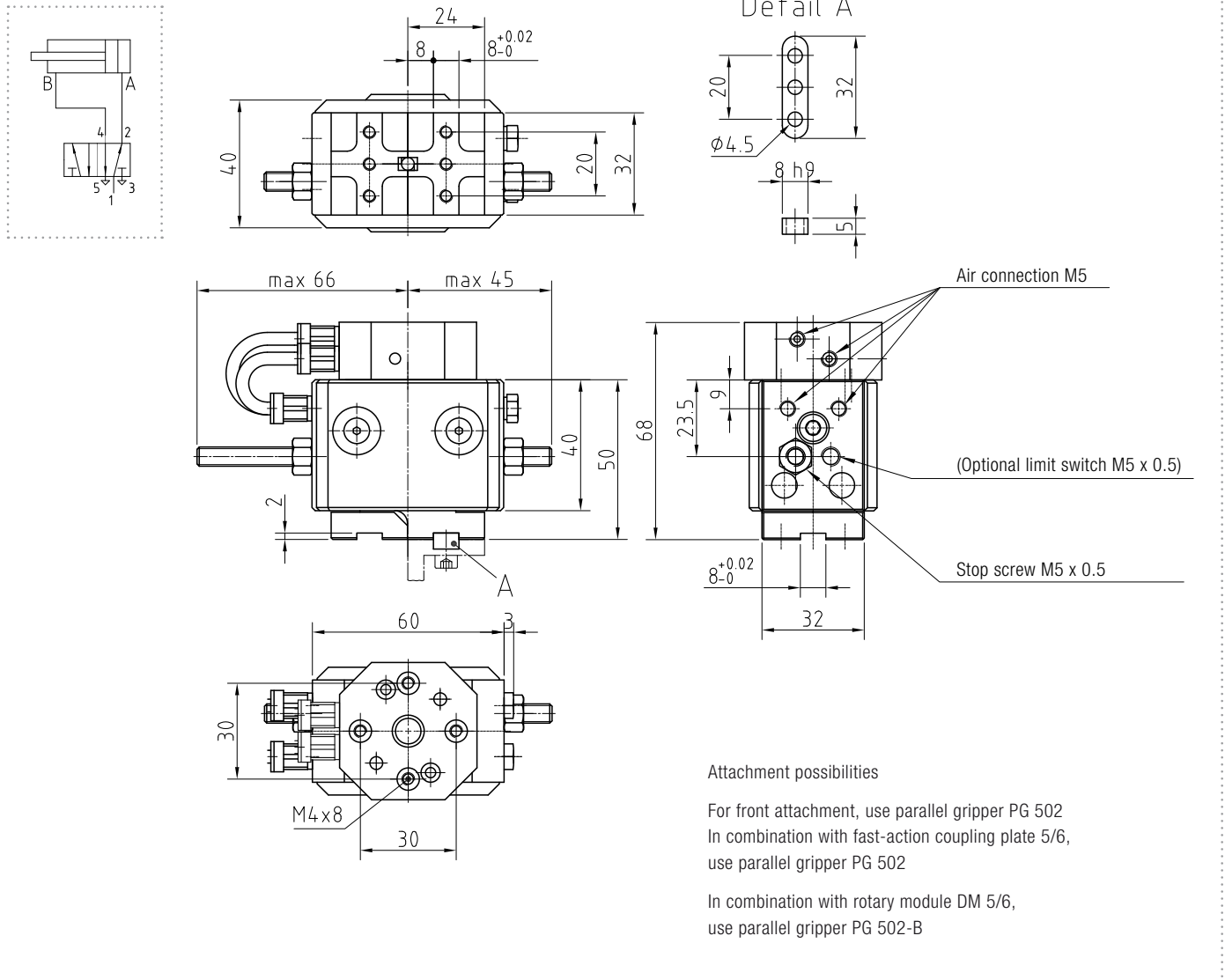

Designation

Order number

PG 402	300 3454	
PG 502	300 5244	incl. connecting plate and centering rings Ø7
PG 502-B	300 5245	incl. 1 pneumatic coupling PK 5/6 and 2 centering couplings ZK 5/6 for combination with rotary module DM 5/6

Accessories

Order number

Centering ring Ø7	300 1521
Limit switch M5x0.5	300 1866
Pneumatic coupling PK5/6	300 4985
Centering coupling ZK5/6	300 2478
Fast-action coupling set SKS5	300 5221
Fast-action coupling set SKS6	300 5223

See chapter Accessories