

## Operating and installation instructions!

# Parallel grippers

### PG 4, PG 5, PG 6

#### Items included in the delivery

The linear module is supplied fully packaged. A listing of delivery contents can be found in the catalog entitled „Domino handling components“.



**Note:**

Deliveries must be checked to ensure they are complete and in perfect condition.

#### Technical data

Please see catalog: „Domino handling components“

#### Safety notes:



**Warning:**

When installing the module, you must switch the power supply off. Both local and product-specific safety instructions must be observed without fail.

#### Installation and assembly PG 4, PG 5, PG 6

##### Setting the sensor, Fig. 1

1. Slacken clamping screws (1), (M2.5=PG4 / M3=PG5 / M3=PG6)
2. Introduce the sensor (2) into the clamping block from above and screw in place securely at a distance of 0.5 mm from the sensor lug (3).



**Caution:**

The sensor is not to contact the sensor lug as it would be damaged. A distance of 0.5 mm must be maintained between the sensor and the sensor lug.

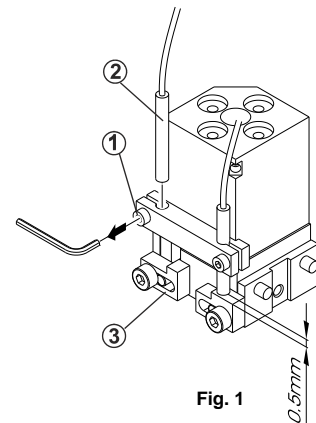

Fig. 1

##### Pneumatic connection (individual use), Fig. 2, 3

1. Remove plug (1) and fit restrictor.
2. Insert sealing plug (2) on the top and lock with clamping pin (3) and locking screw M3 (4).
3. Connect pneumatic hoses according to schematic diagram
4. Adjust restrictor (speed)



**Note:**

Exhaust air throttles must be used without fail in order to comply with permissible operating conditions. The fine adjustment of the throttle valves is to take place according to the manufacturer's instructions!

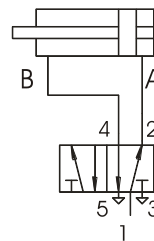

Fig. 2

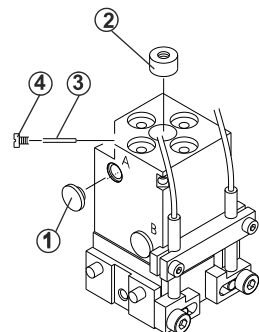

Fig. 3

### Pneumatic connection (use with DM), Fig. 4, 5

1. Slacken locking screw M3 (1) and remove clamping pin (2)
2. Remove sealing plug (3) using a screw (4), (M3=PG4 / M4=PG5 / M4=PG6)
3. Screw centering coupling (5) securely in place from above with Allen screw (6). (M3=PG4 / M4=PG5 / M4=PG6)
4. Fit pneumatic coupling (7) from above and lock with clamping pin (2) and locking screw.
5. Fit blanking plugs M5 (8) to unused valve sockets.



#### Note:

Apply a thin coating of grease to the pneumatic coupling (7) before fitting. By displacing the two centering couplings (5) through 90°, the gripper can be turned through 90° and mounted on the rotary module.

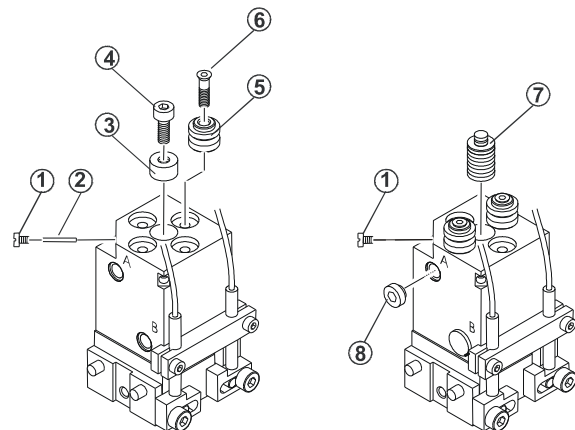

Fig. 4

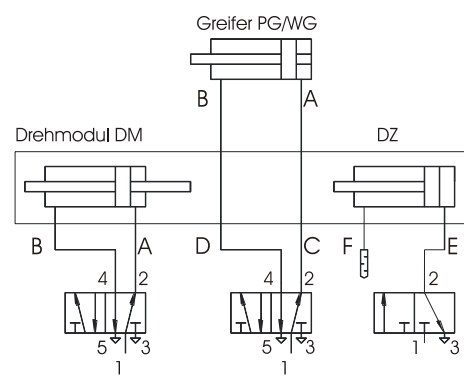

Fig. 5

## Troubleshooting

Problem	Cause / rectification
Gripper does not move	<ul style="list-style-type: none"> <li>▪ Check air supply (3-7bar)</li> <li>▪ Minimum pressure fallen below</li> <li>▪ Air lines interchanged</li> <li>▪ Restrictor valves closed</li> <li>▪ Unused connectors not blanked off</li> <li>▪ Foreign bodies under gripper arms</li> </ul>
Incorrect traversing path	<ul style="list-style-type: none"> <li>▪ Foreign bodies under gripper arms</li> <li>▪ Minimum pressure fallen below</li> </ul>
Module moves jerkily or too fast	<ul style="list-style-type: none"> <li>▪ No restrictor valves or restrictor valves incorrectly set</li> <li>▪ Excessive load (see datasheet in catalogue)</li> </ul>
Module moves too slow	<ul style="list-style-type: none"> <li>▪ Restrictor valves incorrectly set</li> </ul>
Movement force is diminished	<ul style="list-style-type: none"> <li>▪ Check air supply</li> <li>▪ Check seals</li> <li>▪ Clean and lubricate gripper</li> </ul>

## Maintenance

To ensure correct function of the module, please comply with the following instructions:

- The compressed air must be filtered, dry, oiled or oil-free.
- The modules must be regularly checked and cleaned.



#### Note:

We recommend that all metallic sliding surfaces are lightly coated with lubrication grease according to DIN 51825,K2K after ca. 5.mio. cycles.