

Operating and installation instructions Linear module LM 4 S

Items included in the delivery

The linear module is supplied fully packaged. A listing of delivery contents can be found in the catalog entitled "Domino handling components".



Note:

Deliveries must be checked to ensure they are complete and in perfect condition.

Technical data

Please see catalog: "Domino handling components" (max. permissible weight 2kg; max. Speed 0.5m/s)
The technical specifications must be heeded to maximize the service life of the modules.

Safety notes:



Warning:

When installing the module, you must switch the power supply off.
Both local and product-specific safety instructions must be observed without fail.

Installation and integration of LM 4 S



Installation instructions

Warning:

The surface on which the module is installed must be level within a range of $\pm 0.01\text{mm}$.
Uneven areas within this surface greatly affect the service life and accuracy of the modules!

Preliminary work

The precise stop positions are to be specified according to the process documentation (hole matrix 15 mm).

General setup, fig 1

30mm matrix possible from a stroke of 60mm.

1. Detach screw (1) from the stop block (2).
2. Remount the stop block (2) at the new position.

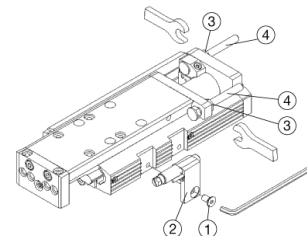

fig 1

Fine adjustment/stop left or right, fig 1

1. Loosen counter nut (3) of stop screw (4).
2. Adjust stop screw (4) to precise travel path. (Adjustment range 0-30 mm)
3. Lock stop screw (4) with counter nut (3).

Adjustment of the reed switch, figure 2

1. Slide the reed switch (1) in the groove (2) to the desired position and secure in place.
2. Connect the reed switch (1) electrically.

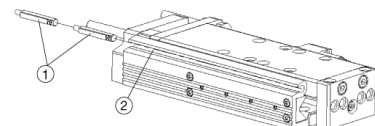

fig 2

Adjustment of limit switch (ES), fig 3

1. Loosen clamping screw (1).
2. Slide limit switch (2) from rear into stop block guide (3) up as far as stop.
3. Retighten clamping screw (1).
4. Connect limit switch (2) to electricity supply.

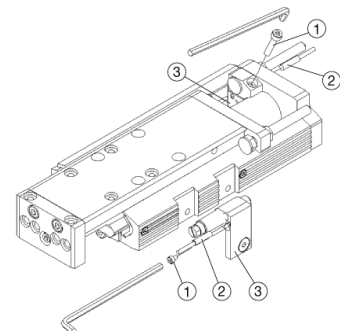

fig 3



Note:

The wiring and connection of the limit switch must be carried out according to the manufacturer's instructions!

Compressed air connection, fig 4, 5

1. Remove the protective stopper M5 (1) from the end plate (2).
2. Fit exhaust air throttle.
3. Connect pneumatic hoses as per diagram; fig 5.
4. Adjust throttle (speed).



Caution:

Exhaust air throttles must be used without fail in order to comply with permissible operating conditions.

Adjust exhaust air throttles in such a way that the carriage travels to the end positions without banging.

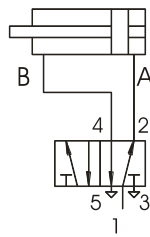

fig 4

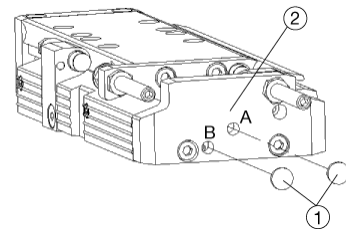

fig 5

Remedying faults

Problem	Cause/Remedy
Module does not move	<ul style="list-style-type: none"> ▪ Check air supply (3 – 7 bar) ▪ Pressure dropped below minimum level ▪ Air lines mixed up ▪ Throttle valves closed ▪ Unused connections not capped ▪ Foreign body between carriage body and stop
Travel path incorrect	<ul style="list-style-type: none"> ▪ Foreign body between carriage body and stop ▪ Pressure dropped below minimum level ▪ Check stops
Module moves jerkily or too quickly	<ul style="list-style-type: none"> ▪ Throttle valves missing or incorrectly set ▪ Load too great (please see data sheet in catalog)
Module moves too slowly	<ul style="list-style-type: none"> ▪ Throttle valves set incorrectly
The motive power is declining	<ul style="list-style-type: none"> ▪ Check air supply ▪ Check seals ▪ Clean and lubricate module

Maintenance and lubrication instructions

To ensure perfect operation of the module the following must be observed:
The compressed air must be filtered, dry, oiled or oilless.
Modules must be inspected and cleaned regularly.

Shock absorbers:



Note:

Top quality shock absorbers are used in the modules! In spite of this, they can still fail occasionally.



Caution:

Make absolutely certain the carriage does not slam into its end position. Should this prove to be the case, the relevant shock absorber must be replaced without delay. Faulty shock absorbers reduce the service life of modules considerably and the accuracy and reproducibility of end positions can no longer be guaranteed.

Relubricating:

The lubrication interval for the guide is approx. 5 million cycles.
Lubrication involves direct application of the lubricant (grease as per Molykote DX Paste) onto the guide tracks and then sliding the carriage in and out several times by hand (repeat procedure 3 to 4 times).



Note:

However, adverse operating conditions (dust, aggressive fluids, vibration, impact stress, corrosion, etc.) can necessitate cleaning and relubricating at an earlier stage.